

VELA ALA LUNA

Technical-Info

APRIL 2019

The logo for Loran, featuring the word "Loran" in a stylized, italicized font with a horizontal line underneath the "L". Below the name is the tagline "everyday passion" in a smaller, lowercase font.

Loran
everyday passion

MODULI

Aggiungere ad ogni elemento il prezzo del supporto a pavimento o a muro, del piano, dell'alzatina, del lavello e del rubinetto.

I moduli su misura possono essere realizzati solo con anta: applicare il prezzo dell'articolo di misura superiore con un supplemento del 25%.

PENSILI E VETRINE

Pensili e vetrine su misura: applicare il prezzo dell'articolo di misura superiore con un supplemento del 25%.

ATTENZIONE

Indicare sempre le misure delle apparecchiature che devono essere inserite nei moduli.

Le composizioni si intendono sempre a partire da sinistra verso destra. Specificare i colori di fusto, frontali e maniglie dei moduli.

Specificare dimensioni e tipo di piano, alzatina, lavello e rubinetto.

Composizioni lineari con canalina tecnica e lavello: utilizzare piani con profondità minima 520 mm.

Per composizioni con elementi ad angolo verificare la perpendicolarità delle pareti (90°): considerando la distanza di 80 cm. su una parete e 60 cm. sull'altra, la diagonale deve corrispondere a 100 cm.

Dimensioni: L = Larghezza P = Profondità H = Altezza

MANIGLIE ALLUMINIO

N.B.: solo in alluminio, **NO** verniciate.

SUPPORTI A PAVIMENTO

N.B.: solo in alluminio, **NO** verniciati.

CORIAN® e STRATIFICATO: solo di colore bianco.

MAGGIORAZIONI DI PREZZO PER COLORAZIONI SPECIALI

Colori RAL metallizzati/perlati e brillanti e in altri colori diversi dalla cartella RAL:

- **Supporto a pavimento/muro** (Vela pag. 15-16): supplemento + € 180,00
- **Kit di trasformazione in servomobile** (Vela pag. 14): supplemento + € 180,00
- **Serie frontali/anta**: supplemento per ogni mobile + € 100,00
- **Pannelli colorati Luna**: supplemento per ogni carrello + € 100,00.

SPESE IMBALLO: ogni collo € 15,00 prezzo netto.

UNITS

Add the floor support or wall support price, the top, splashback, sink and mixer prices to each unit.

Made-to-measure units: apply the price of the article with the next greater size and add a 25% extra charge.

WALL UNITS AND DISPLAY CABINETS

Made-to-measure wall units and display cabinets: apply the price of the article with the next greater size and add a 25% extra charge.

ATTENTION

Always provide the dimensions of the appliances that will be built into the units. The compositions are always understood as starting from the left to the right.

Specify the colours of the unit, front panels and handles.

Specify the dimensions and type of top, splashback, sink and mixer.

Straight compositions with technical raceway and sink: use tops with minimum depth 520 mm.

For compositions with corner elements check that the walls are perfectly perpendicular (90°): considering the distance of 80 cm on the right and 60 cm left hand sides of the corner, the diagonal line must be 100 cm.

Dimensions: L = Width P = Depth
H = Height

ALUMINIUM HANDLE

Attention: only aluminium, **NOT** painted.

FLOOR SUPPORT

Attention: only aluminium, **NOT** painted.

CORIAN® and STRATIFIED: only in white color.

UPCHARGES FOR SPECIAL COLORS

Metallized/pearl and luminous RAL colors and other different colors from the RAL colors:

- **Floor/wall support** (Vela page 15-16): upcharge + € 180,00
- **Sides for movable unit** (Vela page 14): upcharge + € 180,00
- **Fronts/door**: upcharge for each unit + € 100,00
- **Painted panels Luna**: upcharge for each trolley + € 100,00

PACKING COSTS:

each package € 15,00 net price

MODULES

À chaque module il faut ajouter le prix de support au sol au support ou mur, plan, dossier, évier et robinet. Les modules sur mesure peuvent être réalisés uniquement avec une porte: appliquer le prix de l'article de mesure supérieure et ajouter un supplément de 25%.

ÉLÉMENTS MURAUX ET VITRINES

Éléments suspendus et vitrines sur mesure: appliquer le prix de l'article de mesure supérieure et ajouter un supplément de 25%.

ATTENTION

Indiquer obligatoirement les mesures exactes des appareils destinés à être introduits dans les meubles. Les compositions s'entendent toujours en partant de gauche vers la droite. Spécifier les couleurs du corps, des façades et des poignées des modules. Spécifier les dimensions et le type du plan, du dossier, du lavabo et du robinet. Compositions linéaires avec canalisation technique et évier: utiliser des plans ayant une profondeur minimale de 520 mm. Pour les compositions avec des éléments d'angle, contrôler soigneusement la perpendicularité des murs (90°): si on prend la distance exacte de 80 cm à droite et 60 cm à gauche de l'angle, la diagonale devra mesurer 100 cm.

Dimensions: L = Largeur P = Profondeur
H = Hauteur

ALUMINIUM HANDLE

Attention: only aluminium, NOT painted.

FLOOR SUPPORT

Attention: only aluminium, NOT painted.

CORIAN® et STRATIFIE': en couleur blanc seulement.

SUPPLÉMENTS DE PRIX POUR COULEURS SPÉCIALES

Couleurs RAL métallisés/pearl et lumineux et d'autres couleurs différentes des couleurs RAL:
- Support au sol/au mur (Vela page 15-16): supplément de prix + € 180,00
- Côtés pour module mobile (Vela page 14): supplément de prix + € 180,00
- Façades/porte: supplément de prix pour chaque module + € 100,00
- Panneaux peints Luna: supplément de prix pour chaque chariot + € 100,00

FRAIS D'EMBALLAGE:

prix net de chaque colis € 15,00

SCHRÄNKE

Bei jedem Element muss der Preis der Bodengestell oder der Wandbefestigung, der Arbeitsplatte, der Aufkantung, der Spüle und der Wasserhahn separat berechnet werden.

Maßgefertigte Schränke können nur mit Tür hergestellt werden: auf den Preis des nächst größeren Artikels einen Mehrpreis von 25% berechnen.

HÄNGESCHRÄNKE UND VITRINEN

Maßgefertigte Hängeschränke und Vitrinen: auf den Preis des nächst größeren Artikels einen Mehrpreis von 25% berechnen.

VORSICHT

Immer die Maße der Geräte angeben, die in die Schränke eingebaut werden. Die Anbaulösungen sind immer von links nach rechts angegeben. Die Farben des Korpus, der Fronten und der Griffe der Schränke angeben. Abmessungen und Art der Arbeitsplatte, Aufkantung, Spüle und Wasserhahn angeben. Lineare Anbaulösungen mit Technikkanal und Spüle: Arbeitsplatten mit einer Mindesttiefe von 520 mm verwenden. Bei Anbaulösungen mit ECKELEMEN- TEN auf lotrechte (90°) Wände achten: bei einem Abstand von 80 cm rechts und 60 cm links von der Ecke muss die Diagonale 100 cm betragen.

Abmessungen: L = Breite P = Tief
H = Höhe

POIGNÉE EN ALUMINIUM

Attention: en aluminium, PAS peint.

SUPPORTS AU SOL

Attention: en aluminium, PAS peint.

CORIAN® und SCHICHTSTOFF: nur weiß.

AUFPREIS FÜR SONDERFARBEN

Metallic/Perl und leuchtende RAL-Farben und anderen verschiedenen Farben der RAL-Farben:
- Bodengestell/Wandbefestigung (Vela Seite 15-16): Aufpreis + € 180,00
- Seiten für Rollenschrank (Vela Seite 14): Aufpreis + € 180,00
- Fronten/Tür: Aufpreis für jede Schrank + € 100,00
- Lackierte Paneel Luna: Aufpreis für jede Wagen + € 100,00

VERPACKUNGSKOSTEN:

jedes Paket € 15,00 Nettopreis

MÓDULOS

Añadir a cada elemento el precio del soporte de pie o del soporte en pared, de la encimera, de la alzada, del lavabo y del grifo.

Los muebles a la medida pueden realizarse sólo con la puerta: aplicar el precio del artículo de medida superior con un recargo del 25%.

MUEBLES COLGANTES Y VITRINAS

Muebles colgantes y vitrinas a la medida: aplicar el precio del artículo de medida superior con un recargo del 25%.

ATENCIÓN

Indicar siempre las medidas de los equipos que deben introducirse en los módulos. Las composiciones se consideran siempre a partir de la izquierda hacia la derecha. Especificar los colores del módulo, de los frentes y de los tiradores. Especificar las dimensiones y el tipo de encimera, de alzada, de lavabo y de grifo. Composiciones lineales con canal técnico y lavabo: utilizar encimeras con 520 mm de profundidad mínima. Para composiciones con elementos en ángulo controlar la perpendicularidad de las paredes (90°): considerando la distancia de 80 cm a la dcha. y 60 cm a la izq., del ángulo, la diagonal debe corresponder a 100 cm.

Dimensiones: L = Ancho P = Profundidad
H = Alto

ALUMINIUMGRIFF

Bitte beachten: Aluminium, NICHT lackiert.

BODENGESTELL

Bitte beachten: Aluminium, NICHT lackiert.

CORIAN® y ESTRATIFICADO: de color blanco.











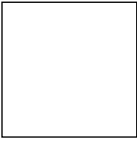
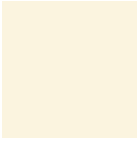







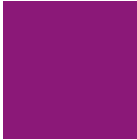







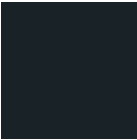

CARGOS ADICIONAL PARA COLORACIONES ESPECIALES

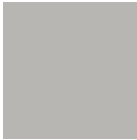
Colores RAL metalizados/perla y brillantes y otros colores diferentes de colores RAL:
- Soporte de pie/en pared (Vela página 15-16): cargo adicional + € 180,00
- Laterales para modulo móvil (Vela página 14): cargo adicional + € 180,00
- Frentes/puerta: cargo adicional por cada módulo + € 100,00
- Paneles pintados Luna: cargo adicional por cada carro + € 100,00

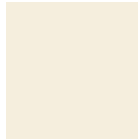
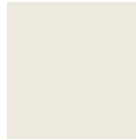
EMBALAJE:

cada paquete € 15,00 precio neto

Finiture verniciate / Painted finishes / Finitions peintes / Lackierten Ausführungen / Acabados pintados

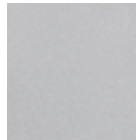
						
BIANCO	RAL 1015	RAL 1018	RAL 1023	RAL 2001	RAL 2012	RAL 3000
						
RAL 3004	RAL 3016	RAL 4002	RAL 4006	RAL 5000	RAL 5002	RAL 5010
						
RAL 5012	RAL 5014	RAL 5022	RAL 5024	RAL 6000	RAL 6019	RAL 6027
						
RAL 7016	RAL 7022	RAL 7038	RAL 7045	RAL 8019	RAL 9001	RAL 9002
						
RAL 9005	SILVER	APRICOT	602 PLA	C3526	GLICINE	SILVER METALLIC

Colorazioni speciali con maggiorazione di prezzo / Special colors with upcharge
 Couleurs spéciales avec supplément de prix / Sonderfarben gegen einem Aufpreis
 Coloraciones especiales disponibles por un cargo adicional

Colori piani in vetro / Colors of the glass tops / Couleurs des plans en verre / Farben der Glasarbeitsplatten / Colores de las encimeras de vidrio

			
TURCHESE	LIMONE	VERDE ACQUA	VERDE
			
CELESTE	BLU CINA	ROSSO GRANATA	ROSSO VENEZIANO

Vetro extra-chiaro / Extra clear glass / Verre transparent / Transparenet Glas / Vidrio transparente

		
GIALLO	AZZURRO MEDITERRANEO	GLICINE
		
SALMONE	GIALLO NEVADA	BIANCO

Disponibile in tutti i colori RAL / Available in all RAL colors

Questo campionario deve essere considerato solo come guida indicativa del colore e non può essere utilizzato come riferimento originale per la produzione e la valutazione di superfici colorate.

This sample should only be considered as an indicative colour guide and cannot be used as an original reference for the production and assessment of colored surfaces.

Ce nuancier ne sert qu'à donner une idée des différents coloris et ne doit en aucun cas être utilisé comme référence originale pour la production et l'évaluation des surfaces colorées.

Diese Farbmuster sind unverbindlich und können vom Original Farbton der hergestellten Oberflächen abweichen.

Esta muestra de colores debe considerarse sólo como una guía indicativa del color, y no puede utilizarse como referencia original para la producción y evaluación de las superficies pintadas.

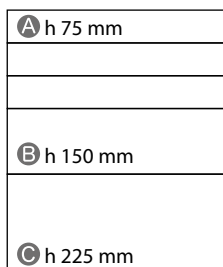
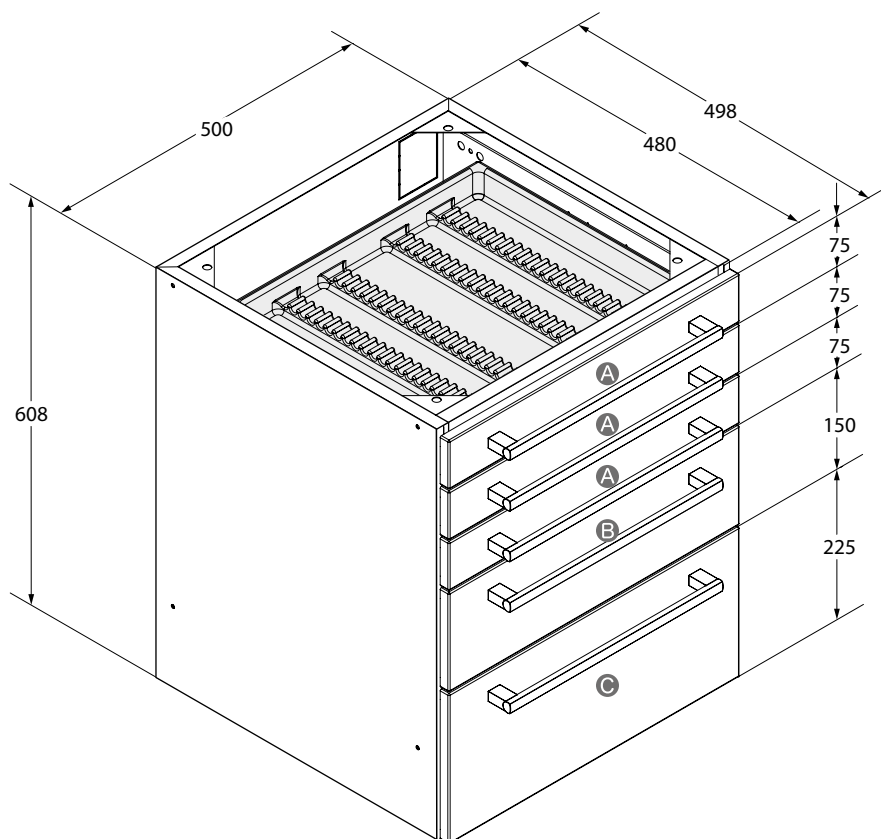

Cassetti
Drawers / Tiroirs
Schubladen / Cajones

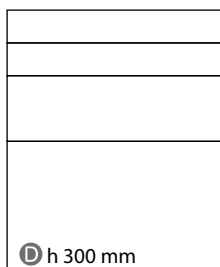

Cassetti
Drawers / Tiroirs
Schubladen / Cajones

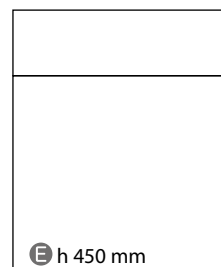

Modulo sottolavello
Sink unit / Module lavabo
Waschbeckenschrank
Módulo bajo lavabo

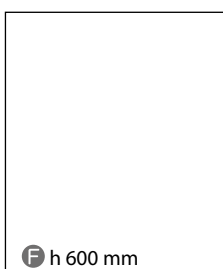

Anta
Door / Porte
Tür / Puerta

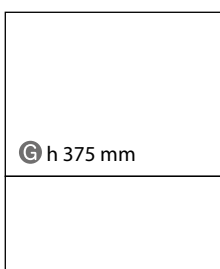

Anta a ribalta
Hide-away door
Porte basculante
Versenkbare Tür
Puerta escamoteable

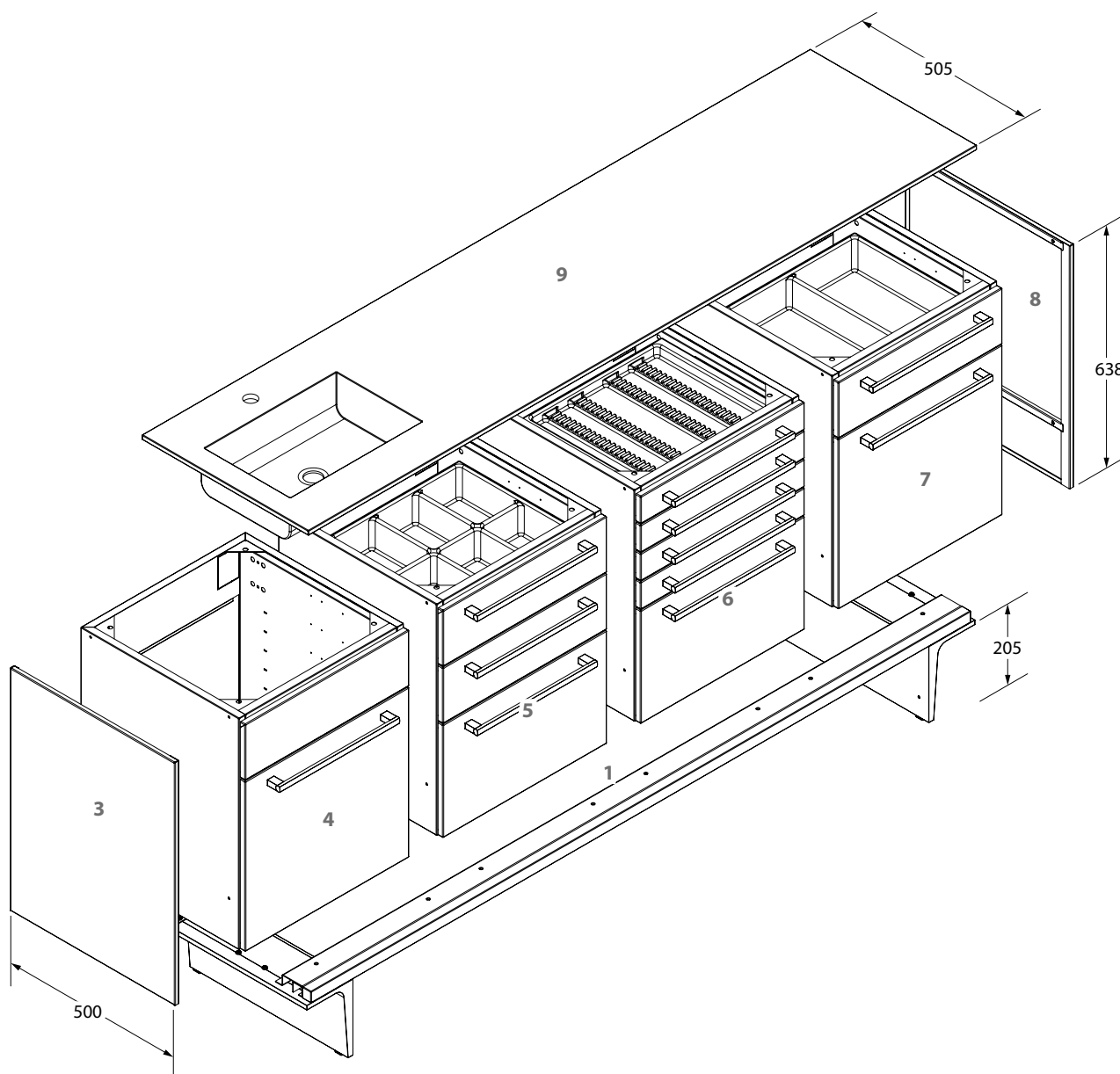

MOBILE VELA

- 1** Supporto a pavimento
- 2** Bordo di finitura per versione a muro
- 3** Fianco laterale
- 4** Mobile lavello
- 5** Mobile con 2 cassetti B + 1D
- 6** Mobile con 4 cassetti A + 1D
- 7** Mobile con 1 cassetto B + anta
- 8** Fianco terminale dx
- 9** Piano con lavello sx
- 10** Sistema di aggancio per versione a muro

H Sottopiano 843 mm

UNIT VELA

- 1** Floor support
- 2** Finish profile for wall support
- 3** Lateral side LH
- 4** Sink unit
- 5** Unit with 2 drawers B + 1 D
- 6** Unit with 4 drawers A + 1 D
- 7** Unit with 1 drawer B + door
- 8** Lateral side RH
- 9** Top with sink on the left side
- 10** Coupling system for wall support

H Under the top 843 mm

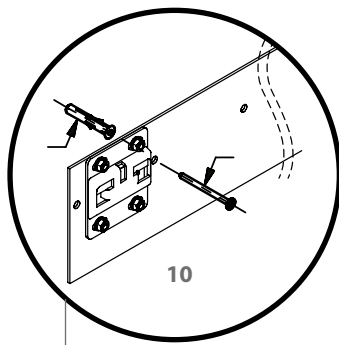

Sistema di aggancio versione sospesa

Coupling system for wall support

Système d'accrochage pour le support au mur

Kupplungssystem für die Wandbefestigung

Placa de soporte para el soporte en pared

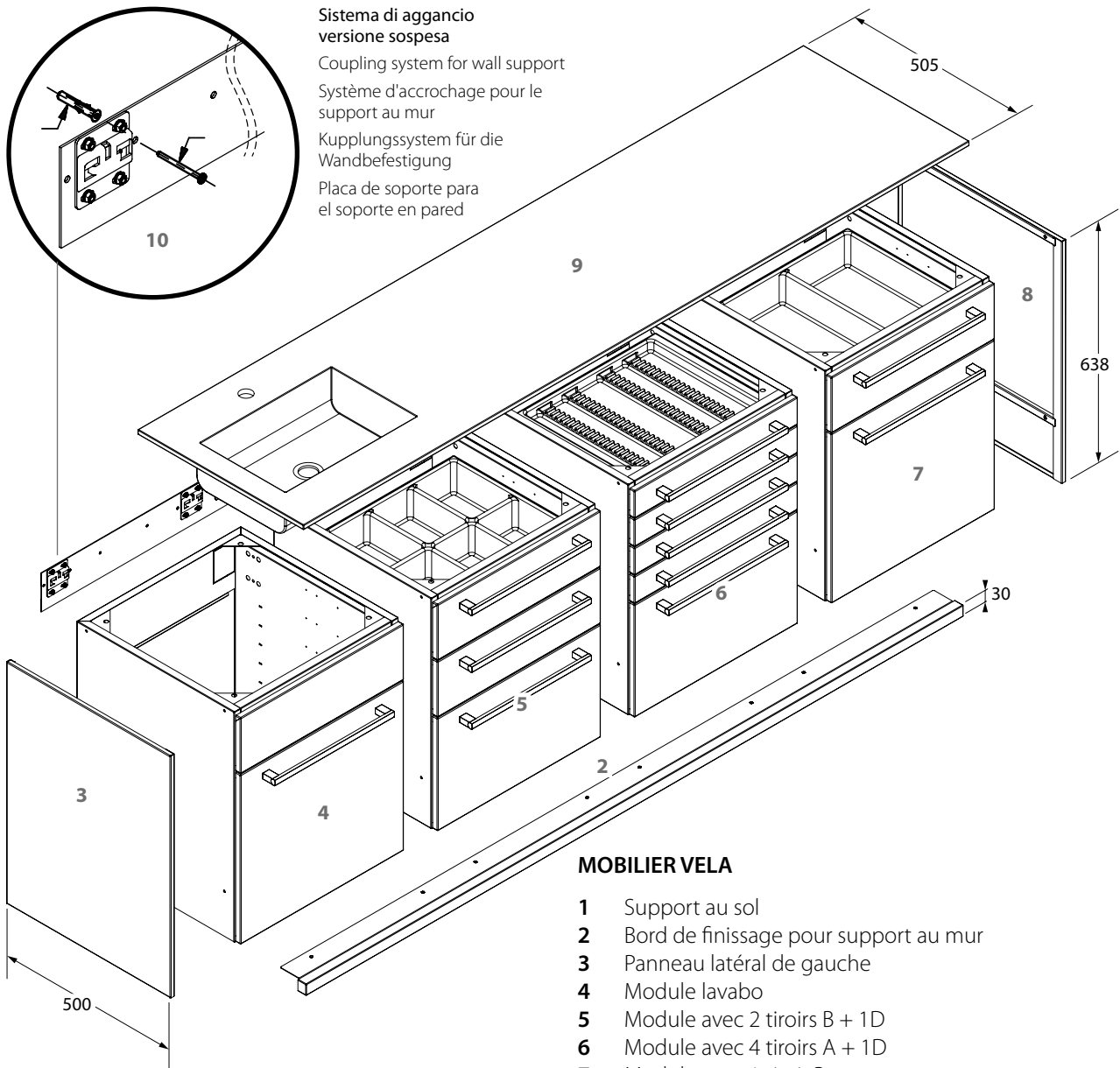

MOBILIER VELA

- 1 Support au sol
 - 2 Bord de finissage pour support au mur
 - 3 Panneau latéral de gauche
 - 4 Module lavabo
 - 5 Module avec 2 tiroirs B + 1D
 - 6 Module avec 4 tiroirs A + 1D
 - 7 Module avec 1 tiroir B et porte
 - 8 Panneau latéral de droite
 - 9 Plan avec évier à gauche
 - 10 Système d'accrochage pour le support au mur
- H** Sous plan de travail 843 mm

VELA-MÖBEL

- 1 Bodengestell
- 2 Abschlussleiste für die Wandbefestigung
- 3 Seitenwand links
- 4 Waschbeckenschrank
- 5 Schrank mit 2 Schubladen B und 1 D
- 6 Schrank mit 4 Schubladen A und 1 D
- 7 Schrank mit 1 Schublade B und Tür
- 8 Seitenwand rechts
- 9 Arbeitsplatte mit Waschbecken links
- 10 Kupplungssystem für die Wandbefestigung

H Unter der Arbeitsplatte 843 mm

MUEBLE VELA

- 1 Soporte de pie
- 2 Borde de acabado para soporte en pared
- 3 Panel lateral izq.
- 4 Módulo bajo lavabo
- 5 Módulo con 2 cajones B + 1D
- 6 Módulo con 4 cajones A + 1D
- 7 Módulo con 1 cajón B + puerta
- 8 Panel lateral dcho.
- 9 Encimera con lavabo izq.
- 10 Placa de soporte para el soporte en pared

A Bajo encimera 843 mm

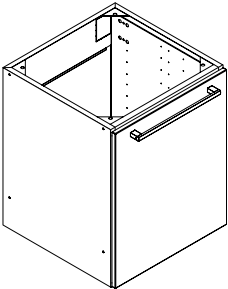
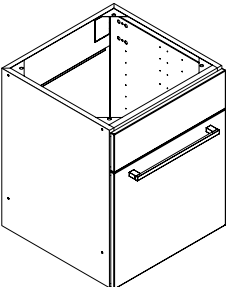
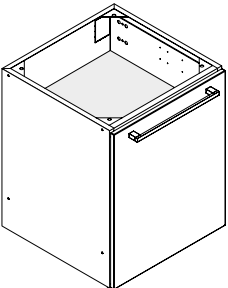
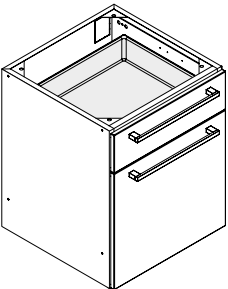
	Descrizione / Description Description / Beschreibung / Descripción	Apertura Opening / Ouverture Öffnung / Apertura	M³ Kg	Articolo Item / Article Artikel / Artículo
 <p>MODULO sottolavello con anta e portarifiuti interno Sink unit with door and rubbish bin Module lavabo avec porte et poubelle Waschbeckenschrank mit Tür und Abfalleimer Módulo lavabo con puerta y cubo de basura</p> <p>L 500 x P 498 x H 608 mm</p>		Maniglia Handle Poignée Griff Tirador	$\frac{0,25}{20,5}$	VLAM
		Push-Pull	$\frac{0,25}{20,3}$	VLAP
 <p>MODULO sottolavello con frontale fisso e anta "VLB" o con cassetto estraibile "VLC", con portarifiuti interno Sink unit with fixed front and door "VLB" or pullout drawer "VLC", with rubbish bin Module lavabo avec façade fixe et porte "VLB" ou grand tiroir extractible "VLC", avec poubelle Waschbeckenschrank mit fest Frontplatte und Tür "VLB" oder Schublade "VLC", mit Abfalleimer Módulo lavabo con frente fijo y puerta "VLB" o cajon "VLC", con cubo de basura</p> <p>L 500 x P 498 x H 608 mm</p>		Maniglia Handle Poignée Griff Tirador	$\frac{0,25}{21}$	VLBM
			$\frac{0,25}{25,5}$	VLCM
			$\frac{0,25}{20,8}$	VLBP
		Push-Pull	$\frac{0,25}{25,3}$	VLCP
 <p>MODULO con anta e due ripiani interni Unit with door and 2 interior shelves Module avec porte et 2 étagères internes Schrank mit Tür und 2 Einlegeböden Módulo con puerta y dos estantes interiores</p> <p>L 500 x P 498 x H 608 mm</p>		Maniglia Handle Poignée Griff Tirador	$\frac{0,25}{20,5}$	VPAM
		Push-Pull	$\frac{0,25}{20,3}$	VPAP
 <p>MODULO con cassetto B e anta con 1 ripiano interno Unit with drawer B and door with an interior shelf Module avec 1 tiroir B et porte avec 1 étagère à l'intérieur Schrank mit 1 Schublade B und Tür mit 1 Einlegeboden Módulo con cajón B y puerta con 1 estante interior</p> <p>L 500 x P 498 x H 608 mm</p>		Maniglia Handle Poignée Griff Tirador	$\frac{0,25}{25}$	VPBM
		Push-Pull	$\frac{0,25}{24,6}$	VPBP

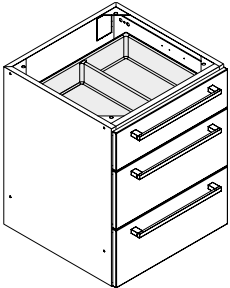
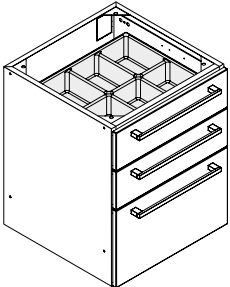
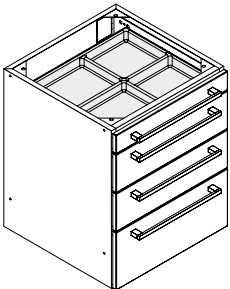
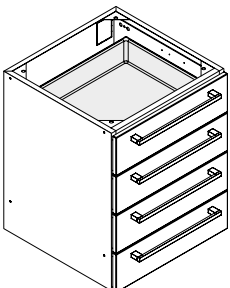
	Descrizione / Description Description / Beschreibung / Descripción	Apertura Opening / Ouverture Öffnung / Apertura	M³ Kg	Articolo Item / Article Artikel / Artículo
 <p>MODULO con 3 cassetti: 1 B e 2 C Unit with 3 drawers: 1 B and 2 C Module avec 3 tiroirs: 1 B et 2 C Schrank mit 3 Schubladen: 1 B und 2 C Módulo con 3 cajones: 1 B y 2 C</p> <p>Bacinelle / Trays / Intérieurs de tiroir / Einsätze / Bandejas: 1xVBB2, 2xVBC1</p>	<p>L 500 x P 498 x H 608 mm</p>	<p>Maniglia Handle Poignée Griff Tirador</p>	<p>0,25 ----- 35,2</p>	V3AM
		<p>Push-Pull</p>	<p>0,25 ----- 34,6</p>	V3AP
 <p>MODULO con 3 cassetti: 2 B e 1 D Unit with 3 drawers: 2 B and 1 D Module avec 3 tiroirs: 2 B et 1 D Schrank mit 3 Schubladen: 2 B und 1 D Módulo con 3 cajones: 2 B y 1 D</p> <p>Bacinelle / Trays / Intérieurs de tiroir / Einsätze / Bandejas: 1xVBB2, 1xVBB4, 1xVBC1</p>	<p>L 500 x P 498 x H 608 mm</p>	<p>Maniglia Handle Poignée Griff Tirador</p>	<p>0,25 ----- 35</p>	V3BM
		<p>Push-Pull</p>	<p>0,25 ----- 34,4</p>	V3BP
 <p>MODULO con 4 cassetti: 1 A, 2 B e 1 C Unit with 4 drawers: 1 A, 2 B and 1 C Module avec 4 tiroirs: 1 A, 2 B et 1 C Schrank mit 4 Schubladen: 1 A, 2 B und 1 C Módulo con 4 cajones: 1 A, 2B y 1 C</p> <p>Bacinelle / Trays / Intérieurs de tiroir / Einsätze / Bandejas: 1xVBA3, 1xVBB1, 1xVBB2, 1xVBC1</p>	<p>L 500 x P 498 x H 608 mm</p>	<p>Maniglia Handle Poignée Griff Tirador</p>	<p>0,25 ----- 40,2</p>	V4AM
		<p>Push-Pull</p>	<p>0,25 ----- 39,4</p>	V4AP
 <p>MODULO con 4 cassetti: 4 B Unit with 4 drawers: 4 B Module avec 4 tiroirs: 4 B Schrank mit 4 Schubladen: 4 B Módulo con 4 cajones: 4 B</p> <p>Bacinelle / Trays / Intérieurs de tiroir / Einsätze / Bandejas: 1xVBB1, 1xVBB2, 1xVBB3, 1xVBB4</p>	<p>L 500 x P 498 x H 608 mm</p>	<p>Maniglia Handle Poignée Griff Tirador</p>	<p>0,25 ----- 40,4</p>	V4BM
		<p>Push-Pull</p>	<p>0,25 ----- 39,6</p>	V4BP

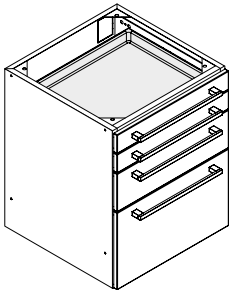
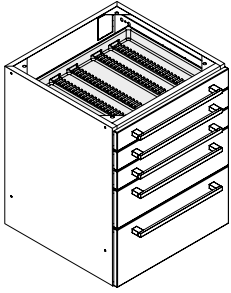
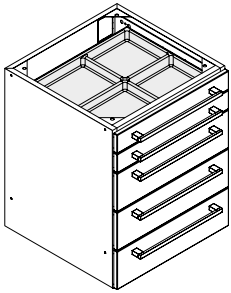
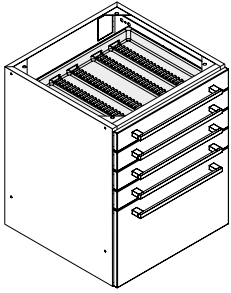
	Descrizione / Description Description / Beschreibung / Descripción	Apertura Opening / Ouverture Öffnung / Apertura	M³ Kg	Articolo Item / Article Artikel / Artículo
 <p>L 500 x P 498 x H 608 mm</p>	<p>MODULO con 4 cassetti: 2 A, 1 B e 1 D Unit with 4 drawers: 2 A, 1 B and 1 D Module avec 4 tiroirs: 2 A, 1 B et 1 D Schrank mit 4 Schubladen: 2 A, 1 B und 1 D Módulo con 4 cajones: 2 A, 1 B y 1 D</p> <p>Bacinelle / Trays / Intérieurs de tiroir Einsätze / Bandejas: 1xVBA2, 1xVBA4, 1xVBB4, 1xVBC1</p>	<p>Maniglia Handle Poignée Griff Tirador</p>	<p>0,25 ----- 39,8</p>	V4CM
		<p>Push-Pull</p>	<p>0,25 ----- 39</p>	V4CP
 <p>L 500 x P 498 x H 608 mm</p>	<p>MODULO con 5 cassetti: 3 A, 1 B e 1 C Unit with 5 drawers: 3 A, 1 B and 1 C Module avec 5 tiroirs: 3 A, 1 B et 1 C Schrank mit 5 Schubladen: 3 A, 1 B und 1 C Módulo con 5 cajones: 3 A, 1 B y 1 C</p> <p>Bacinelle / Trays / Intérieurs de tiroir Einsätze / Bandejas: 1xVBA1, 1xVBA3, 1xVBA4, 1xVBB1, 1xVBC1</p>	<p>Maniglia Handle Poignée Griff Tirador</p>	<p>0,25 ----- 45</p>	V5AM
		<p>Push-Pull</p>	<p>0,25 ----- 44</p>	V5AP
 <p>L 500 x P 498 x H 608 mm</p>	<p>MODULO con 5 cassetti: 2 A e 3 B Unit with 5 drawers: 2 A and 3 B Module avec 5 tiroirs: 2 A et 3 B Schrank mit 5 Schubladen: 2 A und 3 B Módulo con 5 cajones: 2 A y 3 B</p> <p>Bacinelle / Trays / Intérieurs de tiroir Einsätze / Bandejas: 1xVBA3, 1xVBA4, 1xVBB1, 1xVBB2, 1xVBB4</p>	<p>Maniglia Handle Poignée Griff Tirador</p>	<p>0,25 ----- 45,2</p>	V5BM
		<p>Push-Pull</p>	<p>0,25 ----- 44,2</p>	V5BP
 <p>L 500 x P 498 x H 608 mm</p>	<p>MODULO con 5 cassetti: 4 A e 1 D Unit with 5 drawers: 4 A and 1 D Module avec 5 tiroirs: 4 A et 1 D Schrank mit 5 Schubladen: 4 A und 1 D Módulo con 5 cajones: 4 A y 1 D</p> <p>Bacinelle / Trays / Intérieurs de tiroir Einsätze / Bandejas: 1xVBA1, 1xVBA2, 1xVBA3, 1xVBA4, 1xVBC1</p>	<p>Maniglia Handle Poignée Griff Tirador</p>	<p>0,25 ----- 44,6</p>	V5CM
		<p>Push-Pull</p>	<p>0,25 ----- 43,6</p>	V5CP

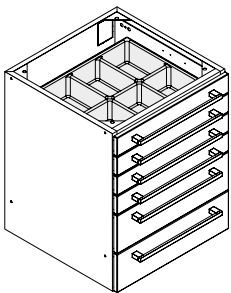
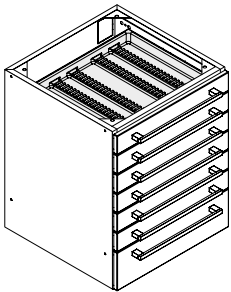
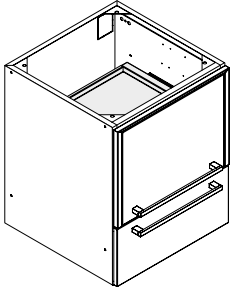
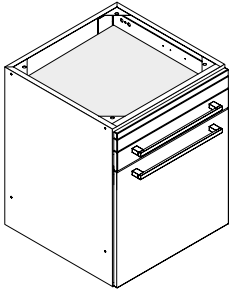
	Descrizione / Description Description / Beschreibung / Descripción	Apertura Opening / Ouverture Öffnung / Apertura	M³ Kg	Articolo Item / Article Artikel / Artículo
 <p>MODULO con 6 cassetti: 4 A e 2 B Unit with 6 drawers: 4 A and 2 B Module avec 6 tiroirs: 4 A et 2 B Schrank mit 6 Schubladen: 4 A und 2 B Módulo con 6 cajones: 4 A y 2 B</p> <p>Bacinelle / Trays / Intérieurs de tiroir / Einsätze / Bandejas: 1xVBA1, 1xVBA2, 1xVBA3, 1xVBA4, 1xVBB1, 1xVBB4</p> <p>L 500 x P 498 x H 608 mm</p>		Maniglia Handle Poignée Griff Tirador	0,25 ----- 50	V6AM
		Push-Pull	0,25 ----- 48,8	V6AP
 <p>MODULO con 7 cassetti: 6 A e 1 B Unit with 7 drawers: 6 A and 1 B Module avec 7 tiroirs: 6 A et 1 B Schrank mit 7 Schubladen: 6 A et 1 B Módulo con 7 cajones: 6 A y 1 B</p> <p>Bacinelle / Trays / Intérieurs de tiroir / Einsätze / Bandejas: 1xVBA1, 2xVBA2, 2xVBA3, 1xVBA4, 1xVBB3</p> <p>L 500 x P 498 x H 608 mm</p>		Maniglia Handle Poignée Griff Tirador	0,25 ----- 54,8	V7AM
		Push-Pull	0,25 ----- 53,4	V7AP
 <p>MODULO con anta a ribalta con 2 ripiani estraibili per apparecchiature + ciabatta con 3 prese di corrente e cassetto C Unit with hide-away door equipped with 2 apparatus storage shelves + 3 Schuko sockets and 1 drawer C Module avec porte basculante avec 2 tiroirs pour appareils + 3 prises de courant Schuko et 1 tiroir C Schrank mit versenkbarer Tür mit 2 Geräteeinlagen + 3 Schuko-Steckdosen und 1 Schublade C Módulo con puerta plegable con 2 estantes extraíbles para equipos + regleta con 3 tomas de corriente Schuko y cajón C</p> <p>L 500 x P 498 x H 608 mm</p>		Maniglia Handle Poignée Griff Tirador	0,25 ----- 33	VRAM
		Push-Pull	0,25 ----- 32,6	VRAP
 <p>MODULO PC con cassetto A per tastiera (L 385 - H 30 mm max), 1 cassetto A e anta, con schiena aperta Unit for PC with 1 drawer A for keyboard (L - H), 1 drawer A and door, open back Module pour PC avec 1 tiroir A pour clavier (L - H), 1 tiroir A et porte, ouvert derrière Schrank für PC mit 1 Schublade A für Tastatur (L - H), 1 Schublade A und Tür, Rückwand geöffnet Módulo PC con 1 cajón A porta teclado (L - H), 1 cajón A y puerta, con panel trasero abierto</p> <p>L 500 x P 498 x H 608 mm</p>		Maniglia Handle Poignée Griff Tirador	0,25 ----- 25	VPCM
		Push-Pull	0,25 ----- 24,8	VPCP

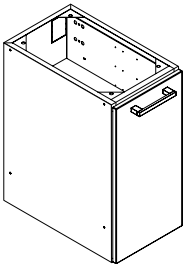
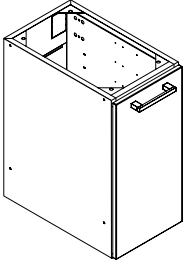
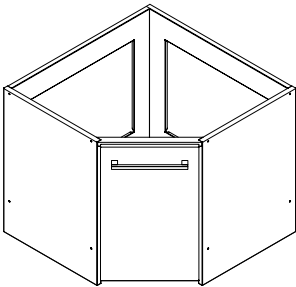
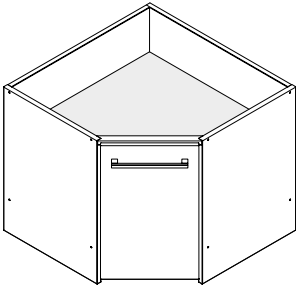
	Descrizione / Description Description / Beschreibung / Descripción	Apertura Opening / Ouverture Öffnung / Apertura	M³ Kg	Articolo Item / Article Artikel / Artículo
 <p>L 300/400 x P 498 x H 608 mm</p>	<p>MODULO con anta e due ripiani interni</p> <p>Unit with door and 2 interior shelves</p> <p>Module avec porte et 2 étagères internes</p> <p>Schrank mit Tür und 2 Einlegeböden</p> <p>Módulo con puerta y dos estantes interiores</p>	Maniglia	0,25	VPDM (L. 300 mm)
		Handle	16	
		Poignée	0,25	VPGM (L. 400 mm)
		Griff	17	
			0,25	VPDP (L. 300 mm)
			15,9	
		Push-Pull	0,25	VPGP (L. 400 mm)
			16,9	
 <p>L 300 x P 498 x H 608 mm</p>	<p>MODULO con anta e due ripiani interni, con schiena aperta</p> <p>Unit with door and 2 interior shelves, open back</p> <p>Module avec porte et 2 étagères internes, ouvert derrière</p> <p>Schrank mit Tür und 2 Einlegeböden, Rückwand geöffnet</p> <p>Módulo con puerta y dos estantes interiores, con panel trasero abierto</p>	Maniglia		VPEM
		Handle		
		Poignée	0,25	VPEM
		Griff	15,5	
			0,23	VPEP
		Push-Pull	15,4	
 <p>L 750 x P 750 x H 608 mm</p>	<p>MODULO angolare sottolavello con anta e portarifiuti interno</p> <p>Corner sink unit with door and rubbish bin</p> <p>Module lavabo d'angle avec porte et poubelle</p> <p>Eckwaschbeckenschrank mit Tür und Abfalleimer</p> <p>Módulo angular lavabo con puerta y cubo de basura</p>	Maniglia		VAAM
		Handle		
		Poignée	0,70	VAAM
		Griff	17,5	
			0,70	VAAP
		Push-Pull	17,4	
 <p>L 750 x P 750 x H 608 mm</p>	<p>MODULO angolare con anta e 1 ripiano interno</p> <p>Corner unit with door and 1 interior shelf</p> <p>Module d'angle avec porte et 1 étagère interne</p> <p>Eckschrank mit Tür und 1 Einlegeboden</p> <p>Módulo angular con puerta y estante interior</p>	Maniglia		VACM
		Handle		
		Poignée	0,70	VACM
		Griff	22	
			0,70	VACP
		Push-Pull	21,9	

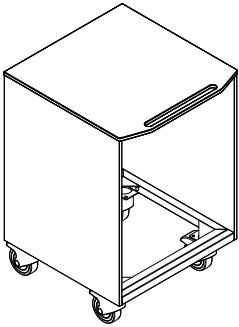
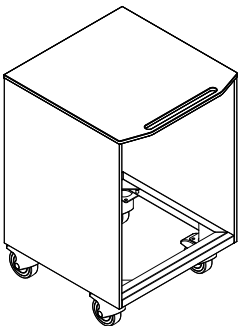
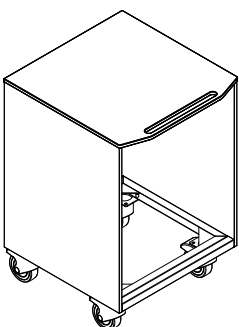
	Descrizione / Description Description / Beschreibung / Descripción	Fianchi Sides / Côtés Seiten / Laterales	M³ Kg	Articolo Item / Article Artikel / Artículo
 <p>Kit ruote + piano sagomato in Corian® bianco</p> <p>Castor set + shaped white Corian® top Kit roues + plan façonné en Corian® blanc Rollenset + Arbeitsplatte aus geformtem weißem Corian® Kit de ruedas + encimera perfilada de Corian® blanco</p> <p>L 528 x P 555 x H 787 mm</p>		Verniciato Painted / Verni Lackiert Pintado	0,08 ----- 21	KRCV
		Stratificato Stratified / Stratifié Schichtstoff Estratificado	0,08 ----- 26,4	KRCS
		Corian®	0,08 ----- 28	KRCC
 <p>Kit ruote + piano sagomato in stratificato bianco</p> <p>Castor set + shaped white stratified top Kit roues + plan façonné en stratifié blanc Rollenset + Arbeitsplatte aus geformtem weißem Schichtstoff Kit de ruedas + encimera perfilada de estratificado blanco</p> <p>L 528 x P 555 x H 787 mm</p>		Verniciato Painted / Verni Lackiert Pintado	0,08 ----- 20,3	KRSV
		Stratificato Stratified / Stratifié Schichtstoff Estratificado	0,08 ----- 25,7	KRSS
		Corian®	0,08 ----- 27,3	KRSC
 <p>Kit ruote + piano sagomato in vetro</p> <p>Castor set + shaped glass top Kit roues + plan façonné en verre Rollenset + geformte Glasarbeitsplatte Kit de ruedas + encimera perfilada de vidrio</p> <p>L 528 x P 555 x H 790 mm</p>		Verniciato Painted / Verni Lackiert Pintado	0,08 ----- 25,6	KRWV
		Stratificato Stratified / Stratifié Schichtstoff Estratificado	0,08 ----- 31	KRVS
		Corian®	0,08 ----- 32,6	KRVC
	MAGGIORAZIONI per piano in vetro Additional charge for glass top Supplément de prix pour plan en verre Aufpreis für Glasarbeitsplatte Cargo adicional para encimera de vidrio	Extra-chiaro Extra clear Transparent Transparente		
		Satinato Satin / Dépoli Satinert Satinado		

VELA | Supporti a pavimento

Floor supports / Supports au sol / Bodengestelle / Soportes de pie

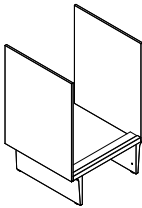
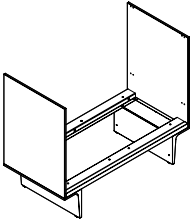
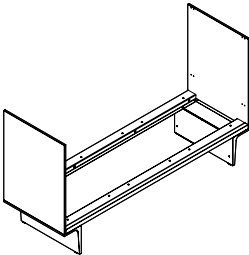
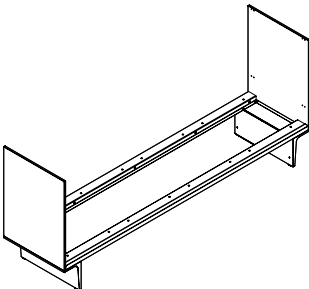
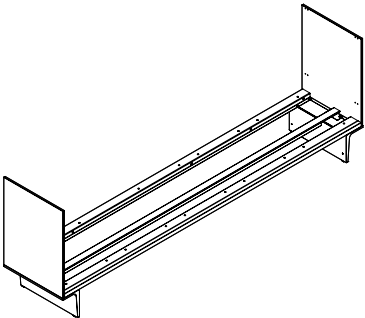
	Descrizione / Description Description / Beschreibung / Descripción	Fianchi Sides / Côtés Seiten / Laterales	M³ Kg	Articolo Item / Article Artikel / Artículo
 <p>L 528 mm</p>	<p>SUPPORTO a pavimento per 1 modulo Floor support for 1 unit Support au sol pour 1 module Bodengestell für 1 Schrank Soporte de pie para 1 módulo</p>	Verniciato Painted / Verni Lackiert Pintado	0,14 26	VS1V
		Stratificato Stratified / Stratifié Schichtstoff Estratificado	0,14 31	VS1S
		Corian®	0,14 33	VS1C
 <p>L 1028 mm</p>	<p>SUPPORTO a pavimento per 2 moduli Floor support for 2 units Support au sol pour 2 modules Bodengestell für 2 Schränke Soporte de pie para 2 módulos</p>	Verniciato Painted / Verni Lackiert Pintado	0,26 34	VS2V
		Stratificato Stratified / Stratifié Schichtstoff Estratificado	0,26 39	VS2S
		Corian®	0,26 41	VS2C
 <p>L 1528 mm</p>	<p>SUPPORTO a pavimento per 3 moduli Floor support for 3 units Support au sol pour 3 modules Bodengestell für 3 Schränke Soporte de pie para 3 módulos</p>	Verniciato Painted / Verni Lackiert Pintado	0,35 38	VS3V
		Stratificato Stratified / Stratifié Schichtstoff Estratificado	0,35 43	VS3S
		Corian®	0,35 45	VS3C
 <p>L 2028 mm</p>	<p>SUPPORTO a pavimento per 4 moduli Floor support for 4 units Support au sol pour 4 modules Bodengestell für 4 Schränke Soporte de pie para 4 módulos</p>	Verniciato Painted / Verni Lackiert Pintado	0,40 42	VS4V
		Stratificato Stratified / Stratifié Schichtstoff Estratificado	0,40 47	VS4S
		Corian®	0,40 49	VS4C
 <p>L 2528 mm</p>	<p>SUPPORTO a pavimento per 5 moduli Floor support for 5 units Support au sol pour 5 modules Bodengestell für 5 Schränke Soporte de pie para 5 módulos</p>	Verniciato Painted / Verni Lackiert Pintado	0,54 57	VS5V
		Stratificato Stratified / Stratifié Schichtstoff Estratificado	0,54 62	VS5S
		Corian®	0,54 64	VS5C

VELA | Supporti a muro

Wall supports / Supports au mur / Wandbefestigungen / Soportes de pared

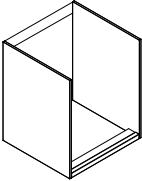
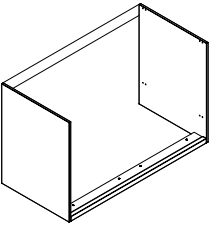
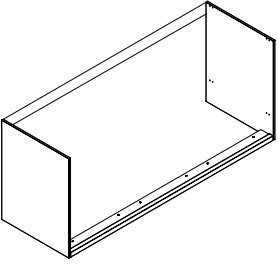
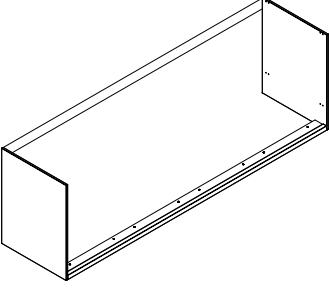
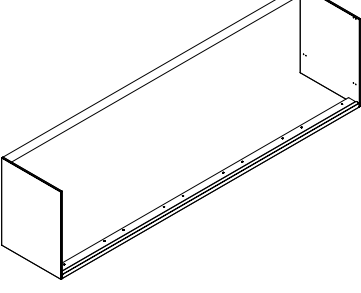
	Descrizione / Description Description / Beschreibung / Descripción	Fianchi Sides / Côtés Seiten / Laterales	M³ Kg	Articolo Item / Article Artikel / Artículo
 <p>L 528 mm</p>	<p>SUPPORTO a muro per 1 modulo Wall support for 1 unit Support au mur pour 1 module Wandbefestigung für 1 Schrank Soporte de pared para 1 módulo</p>	Verniciato Painted / Verni Lackiert Pintado	$\frac{0,01}{10}$	VM1V
		Stratificato Stratified / Stratifié Schichtstoff Estratificado	$\frac{0,01}{15}$	VM1S
		Corian®	$\frac{0,01}{17}$	VM1C
 <p>L 1028 mm</p>	<p>SUPPORTO a muro per 2 moduli Wall support for 2 units Support au mur pour 2 modules Wandbefestigung für 2 Schränke Soporte de pared para 2 módulos</p>	Verniciato Painted / Verni Lackiert Pintado	$\frac{0,02}{12,5}$	VM2V
		Stratificato Stratified / Stratifié Schichtstoff Estratificado	$\frac{0,02}{17,5}$	VM2S
		Corian®	$\frac{0,02}{19,5}$	VM2C
 <p>L 1528 mm</p>	<p>SUPPORTO a muro per 3 moduli Wall support for 3 units Support au mur pour 3 modules Wandbefestigung für 3 Schränke Soporte de pared para 3 módulos</p>	Verniciato Painted / Verni Lackiert Pintado	$\frac{0,03}{14,5}$	VM3V
		Stratificato Stratified / Stratifié Schichtstoff Estratificado	$\frac{0,03}{19,5}$	VM3S
		Corian®	$\frac{0,03}{21,5}$	VM3C
 <p>L 2028 mm</p>	<p>SUPPORTO a muro per 4 moduli Wall support for 4 units Support au mur pour 4 modules Wandbefestigung für 4 Schränke Soporte de pared para 4 módulos</p>	Verniciato Painted / Verni Lackiert Pintado	$\frac{0,04}{17}$	VM4V
		Stratificato Stratified / Stratifié Schichtstoff Estratificado	$\frac{0,04}{22}$	VM4S
		Corian®	$\frac{0,04}{24}$	VM4C
 <p>L 2528 mm</p>	<p>SUPPORTO a muro per 5 moduli Wall support for 5 units Support au mur pour 5 modules Wandbefestigung für 5 Schränke Soporte de pared para 5 módulos</p>	Verniciato Painted / Verni Lackiert Pintado	$\frac{0,05}{21}$	VM5V
		Stratificato Stratified / Stratifié Schichtstoff Estratificado	$\frac{0,05}{26}$	VM5S
		Corian®	$\frac{0,05}{28}$	VM5C

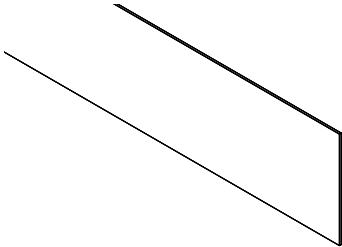
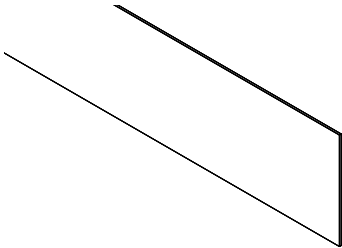
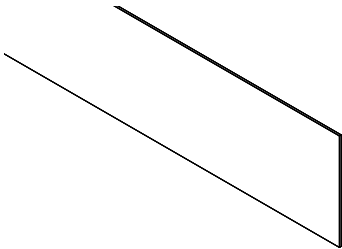
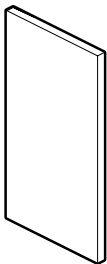
	Descrizione / Description Description / Beschreibung / Descripción	M ³ Kg	Articolo Item / Article Artikel / Artículo
 <p>P 12 x H 638 mm</p>	<p>Tamponamento posteriore verniciato: al metro lineare</p> <p>Painted closing back panel: per meter Cache de fermeture à l'arrière, verni: au mètre Lackierte Verschlußverkleidung: je Meter Panel trasero, pintado: al m.</p>	- 5	VTV
 <p>P 12 x H 638 mm</p>	<p>Tamponamento posteriore in stratificato: al metro lineare</p> <p>Stratified closing back panel: per meter Cache de fermeture à l'arrière, en stratifié: au mètre Verschlußverkleidung aus Schichtstoff: je Meter Panel trasero, de estratificado: al m.</p>	- 8	VTS
 <p>P 12 x H 638 mm</p>	<p>Tamponamento posteriore in Corian®: al metro lineare</p> <p>Corian® closing back panel: per meter Cache de fermeture à l'arrière, en Corian®: au mètre Verschlußverkleidung aus Corian®: je Meter Panel trasero, de Corian®: al m.</p>	- 10	VTC
 <p>L 30 x P 480 x H 843 mm</p>	<p>Pannello laterale verniciato di sostegno piano</p> <p>Painted top-support side panel Panneau latéral verni, de support pour le plan Lackierte Abschlußverkleidung Panel lateral pintado para el soporte de la encimera</p>	- 8	VSL

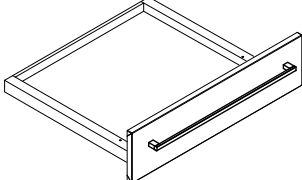
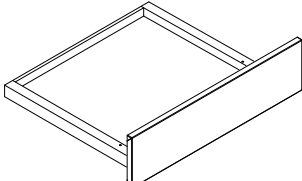
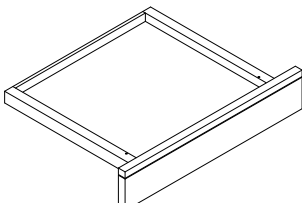
	Descrizione / Description Description / Beschreibung / Descripción		M³ Kg	Articolo Item / Article Artikel / Artículo
	CASSETTO con maniglia Drawer with handle Tiroir avec poignée Schublade mit Griff Cajón con tirador	A) H 75	- 5,7	VCAAM
		B) H 150	- 6,6	VCABM
		C) H 225	- 7,3	VCACM
		D) H 300	- 7,8	VCADM
	CASSETTO Push-Pull Drawer Push-Pull Tiroir Push-Pull Schublade Push-Pull Cajón Push-Pull	A) H 75	- 5,5	VCAAP
		B) H 150	- 6,4	VCABP
		C) H 225	- 7,1	VCACP
		D) H 300	- 7,6	VCADP
	CASSETTO per tastiera (L 385 - H 30 mm max) Drawer for keyboard (L 385 - H 30 mm) Tiroir pour clavier (L 385 - H 30 mm) Schublade für Tastatur (L 385 - H 30 mm) Cajón porta teclado (L 385 - H 30 mm)	A) H 75	- 5,5	VCAAPK

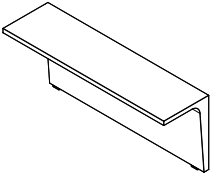
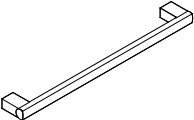
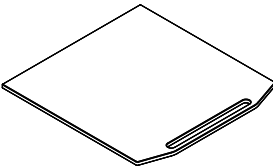
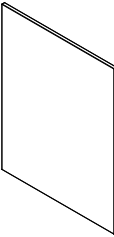
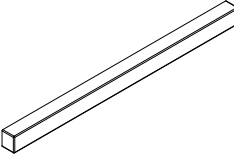
	Descrizione / Description Description / Beschreibung / Descripción		M³ Kg	Articolo Item / Article Artikel / Artículo
	PIEDE in alluminio Aluminium foot Pied en aluminium Aluminiumfuß Pata de aluminio	DX / RH Droite / Rechts Dcho	- 8	VPAD
		SX / LH Gauche / Links Izq	- 8	VPAS
	MANIGLIA in alluminio per "Vela" Aluminium handle for "Vela" Poignée en aluminium pour "Vela" Griff aus Aluminium für "Vela" Tirador de aluminio para "Vela"		- 0,4	MA010
	PIANO sagomato per servomobile Shaped top for movable unit Plan façonné pour module mobile Geformte Arbeitsplatte für Rollenschrank Encimera perfilada para módulo móvil	Stratificato Stratifié / Stratifié Schichtstoff Estratificado	- 5,5	VPSS
		Corian®	- 6,2	VPSC
		Vetro / Glass Verre / Glas / Vidrio	- 10,8	VPSV
		Extra-chiaro Extra clear Transparent Transparent Extra-claro		
		Satinato / Satin Dépoli / Satiniert Satinado		
	FIANCO laterale Lateral side Panneau latéral Seitenwand Panel lateral	Verniciato Painted / Verni Lackiert / Pintado	- 3,5	VFV
		Stratificato Stratifié / Stratifié Schichtstoff Estratificado	- 6,1	VFS
		Corian®	- 6,9	VFC
	BORDO di finitura (ogni modulo) Finish profile (each unit) Bord de finissage (chaque module) Abschlussleiste (jedes Schrank) Borde de acabado (cada módulo)	Verniciato Painted / Verni Lackiert / Pintado	- 0,7	BPV05
		Stratificato Stratifié / Stratifié Schichtstoff Estratificado	- - -	BPS05
		Corian®	- -	BPC05

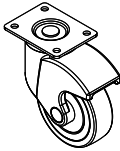
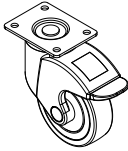
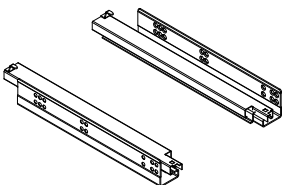
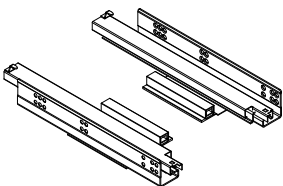
	Descrizione / Description Description / Beschreibung / Descripción	M³ Kg	Articolo Item / Article Artikel / Artículo
	<p>RUOTA senza freno Castor without brake Roue sans frein Rad ohne Bremse Rueda sin freno</p>	<p>- ----- 0,6</p>	<p>RUO26</p>
	<p>RUOTA con freno Castor with brake Roue avec frein Rad mit Bremse Rueda con freno</p>	<p>- ----- 0,7</p>	<p>RUO27</p>
	<p>COPPIA DI GUIDE con rientro ammortizzato Pair of guides with soft closing Couple de glissières avec amortisseur Eine Paar Führungen mit Softeinzug Par de guías con cierre suave</p>	<p>- ----- 1,7</p>	<p>GUI33</p>
	<p>COPPIA DI GUIDE per cassetto Push-Pull Pair of guides for Push-Pull drawer Couple de glissières pour tiroir Push-Pull Eine Paar Führungen für Push-Pull Schublade Par de guías para cajón Push-Pull</p>	<p>- ----- 1,9</p>	<p>GUI24</p>

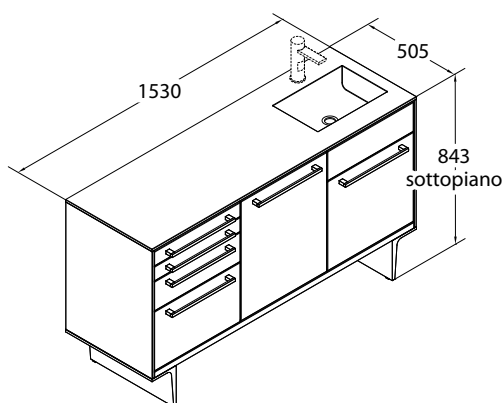

A

COMPOSIZIONE / COMPOSITION / COMPOSITION
ZUSAMMENSTELLUNG / COMPOSICIÓN

V4C + VPA + VLB

La composizione è comprensiva di bacinelle standard. Rubinetto escluso.

Trays included. Mixer excluded.
Intérieurs de tiroirs inclus. Robinet pas compris.
Standard Schubladeneinsätze sind enthalten. Armatur ist ausgeschlossen.
La composición incluye bandejas estándar.
Grifo excluido.

	Con piedi / On feet Sur pieds / Mit Füßen / Con patas		Sospesa / Suspended / Suspendue Wandhängend / Suspendida	
	Maniglia Handle / Poignée Griff / Tirador	Push-Pull	Maniglia Handle / Poignée Griff / Tirador	Push-Pull
1 Piano in stratificato e fianchi verniciati Stratified top and painted sides / Plan stratifié et panneaux latéraux vernis / Arbeitsplatte aus Schichtstoff und lackierte Seitenwände / Encimera de estratificado y laterales pintados	+ VFA			
2 Piano in vetro e fianchi verniciati Glass top and painted sides / Plan en verre et côtés peints / Arbeitsplatte aus Glas und lackierte Seitenwände / Encimera de vidrio y laterales pintados	+ VIV			
3 Piano in Corian® e fianchi verniciati Corian® top and painted sides / Plan en Corian® et panneaux latéraux vernis / Arbeitsplatte aus Corian® und lackierte Seitenwände / Encimera de Corian® y laterales pintados	+ VIC			
4 Piano e fianchi in Corian® Corian® top and Corian® sides / Plan et panneau latéraux en Corian® / Arbeitsplatte und Seitenwände aus Corian® / Encimera y laterales de Corian®	+ VIC			

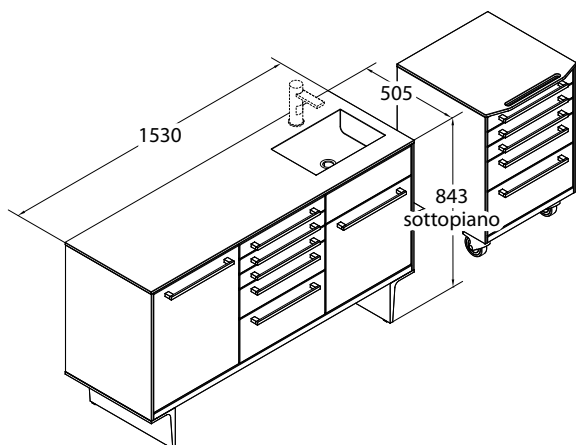

B

COMPOSIZIONE / COMPOSITION / COMPOSITION
ZUSAMMENSTELLUNG / COMPOSICIÓN

VPA + V5A + VLB + V5A + KR

La composizione è comprensiva di bacinelle standard. Rubinetto escluso.

Trays included. Mixer excluded.
Intérieurs de tiroirs inclus. Robinet pas compris.
Standard Schubladeneinsätze sind enthalten. Armatur ist ausgeschlossen.
La composición incluye bandejas estándar.
Grifo excluido.

	Con piedi / On feet Sur pieds / Mit Füßen / Con patas		Sospesa / Suspended / Suspendue Wandhängend / Suspendida	
	Maniglia Handle / Poignée Griff / Tirador	Push-Pull	Maniglia Handle / Poignée Griff / Tirador	Push-Pull
1 Piano in stratificato e fianchi verniciati Stratified top and painted sides / Plan stratifié et panneaux latéraux vernis / Arbeitsplatte aus Schichtstoff und lackierte Seitenwände / Encimera de estratificado y laterales pintados	+ VFA			
2 Piano in vetro e fianchi verniciati Glass top and painted sides / Plan en verre et côtés peints / Arbeitsplatte aus Glas und lackierte Seitenwände / Encimera de vidrio y laterales pintados	+ VIV			
3 Piano in Corian® e fianchi verniciati Corian® top and painted sides / Plan en Corian® et panneaux latéraux vernis / Arbeitsplatte aus Corian® und lackierte Seitenwände / Encimera de Corian® y laterales pintados	+ VIC			
4 Piano e fianchi in Corian® Corian® top and Corian® sides / Plan et panneau latéraux en Corian® / Arbeitsplatte und Seitenwände aus Corian® / Encimera y laterales de Corian®	+ VIC			

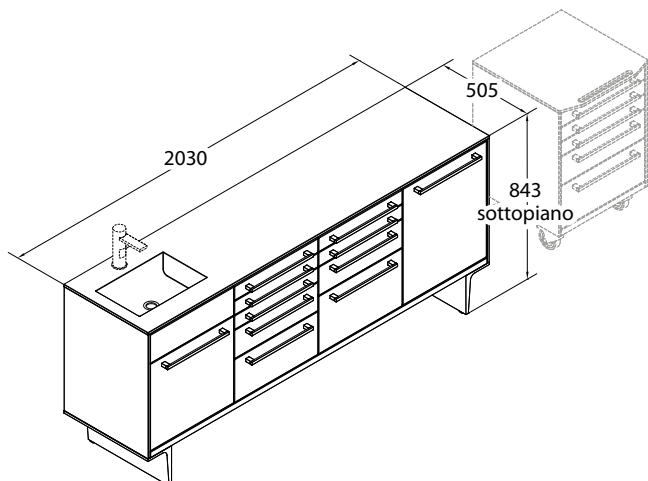

COMPOSIZIONE / COMPOSITION / COMPOSITION
ZUSAMMENSTELLUNG / COMPOSICIÓN

VLB + V5A + V4C + VPA

La composizione è comprensiva di bacinelle standard. Rubinetto escluso.

Trays included. Mixer excluded
Intérieurs de tiroirs inclus. Robinet pas compris.
Standard Schubladeneinsätze sind enthalten. Armatur ist ausgeschlossen.
La composición incluye bandejas estándar. Grifo excluido.

Con piedi / On feet Sur pieds / Mit Füßen / Con patas		Sospesa / Suspended / Suspendue Wandhängend / Suspendida	
Maniglia Handle / Poignée Griff / Tirador	Push-Pull	Maniglia Handle / Poignée Griff / Tirador	Push-Pull

1	Piano in stratificato e fianchi verniciati Stratified top and painted sides / Plan stratifié et panneaux latéraux vernis / Arbeitsplatte aus Schichtstoff und lackierte Seitenwände / Encimera de estratificado y laterales pintados	+ VFA			
2	Piano in vetro e fianchi verniciati Glass top and painted sides / Plan en verre et côtés peints / Arbeitsplatte aus Glas und lackierte Seitenwände / Encimera de vidrio y laterales pintados	+ VIV			
3	Piano in Corian® e fianchi verniciati Corian® top and painted sides / Plan en Corian® et panneaux latéraux vernis / Arbeitsplatte aus Corian® und lackierte Seitenwände / Encimera de Corian® y laterales pintados	+ VIC			
4	Piano e fianchi in Corian® Corian® top and Corian® sides / Plan et panneau latéraux en Corian® / Arbeitsplatte und Seitenwände aus Corian® / Encimera y laterales de Corian®	+ VIC			

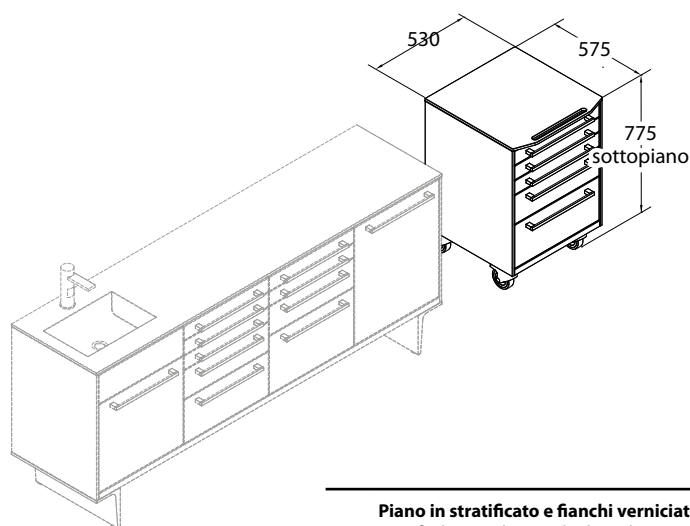

COMPOSIZIONE / COMPOSITION / COMPOSITION
ZUSAMMENSTELLUNG / COMPOSICIÓN

V5A + KR

La composizione è comprensiva di bacinelle standard.

Trays included.
Intérieurs de tiroirs inclus.
Standard Schubladeneinsätze sind enthalten.
La composición incluye bandejas estándar.

Maniglia Handle / Poignée Griff / Tirador	Push-Pull
---	-----------

1	Piano in stratificato e fianchi verniciati Stratified top and painted sides / Plan stratifié et panneaux latéraux vernis / Arbeitsplatte aus Schichtstoff und lackierte Seitenwände / Encimera de estratificado y laterales pintados		
2	Piano in vetro e fianchi verniciati Glass top and painted sides / Plan en verre et côtés peints / Arbeitsplatte aus Glas und lackierte Seitenwände / Encimera de vidrio y laterales pintados		
3	Piano in Corian® e fianchi verniciati Corian® top and painted sides / Plan en Corian® et panneaux latéraux vernis / Arbeitsplatte aus Corian® und lackierte Seitenwände / Encimera de Corian® y laterales pintados		
4	Piano e fianchi in Corian® Corian® top and Corian® sides / Plan et panneau latéraux en Corian® / Arbeitsplatte und Seitenwände aus Corian® / Encimera y laterales de Corian®		

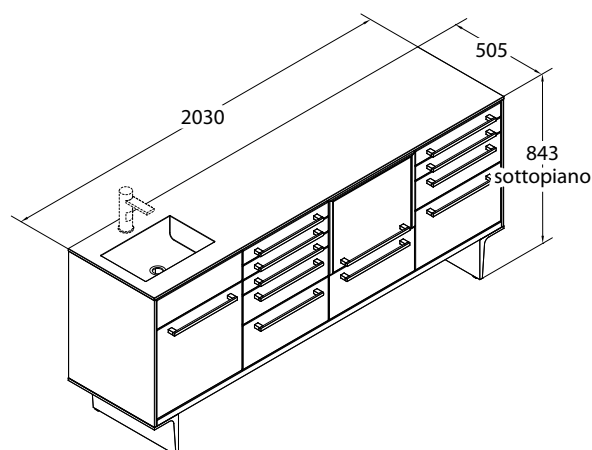

D

COMPOSIZIONE / COMPOSITION / COMPOSITION
ZUSAMMENSTELLUNG / COMPOSICIÓN

VLB + V5A + VRA + V4C

La composizione è comprensiva di bacinelle standard. Rubinetto escluso.

Trays included. Mixer excluded
Intérieurs de tiroirs inclus. Robinet pas compris.
Standard Schubladeneinsätze sind enthalten. Armatur ist ausgeschlossen.
La composición incluye bandejas estándar.
Grifo excluido.

	Con piedi / On feet Sur pieds / Mit Füßen / Con patas		Sospesa / Suspended / Suspendue Wandhängend / Suspendida	
	Maniglia Handle / Poignée Griff / Tirador	Push-Pull	Maniglia Handle / Poignée Griff / Tirador	Push-Pull
1 Piano in stratificato e fianchi verniciati Stratified top and painted sides / Plan stratifié et panneaux latéraux vernis / Arbeitsplatte aus Schichtstoff und lackierte Seitenwände / Encimera de estratificado y laterales pintados	+ VFA			
2 Piano in vetro e fianchi verniciati Glass top and painted sides / Plan en verre et côtés peints / Arbeitsplatte aus Glas und lackierte Seitenwände / Encimera de vidrio y laterales pintados	+ VIV			
3 Piano in Corian® e fianchi verniciati Corian® top and painted sides / Plan en Corian® et panneaux latéraux vernis / Arbeitsplatte aus Corian® und lackierte Seitenwände / Encimera de Corian® y laterales pintados	+ VIC			
4 Piano e fianchi in Corian® Corian® top and Corian® sides / Plan et panneau latéraux en Corian® / Arbeitsplatte und Seitenwände aus Corian® / Encimera y laterales de Corian®	+ VIC			

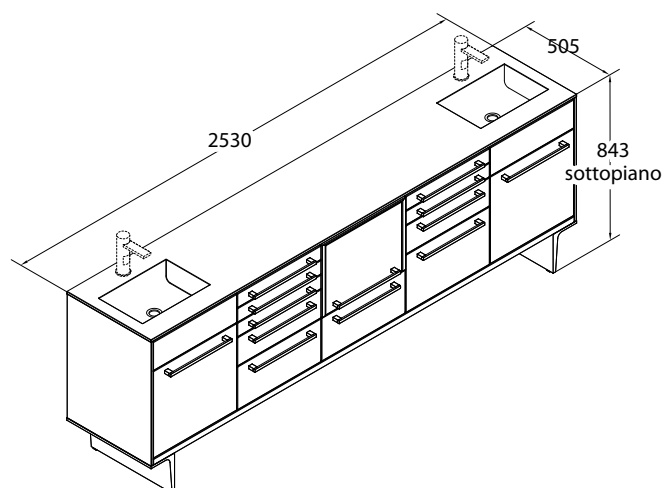

E

COMPOSIZIONE / COMPOSITION / COMPOSITION
ZUSAMMENSTELLUNG / COMPOSICIÓN

VLB + V5A + VRA + V4C + VLB

La composizione è comprensiva di bacinelle standard. Rubinetto escluso.

Trays included. Mixer excluded
Intérieurs de tiroirs inclus. Robinet pas compris.
Standard Schubladeneinsätze sind enthalten. Armatur ist ausgeschlossen.
La composición incluye bandejas estándar.
Grifo excluido.

	Con piedi / On feet Sur pieds / Mit Füßen / Con patas		Sospesa / Suspended / Suspendue Wandhängend / Suspendida	
	Maniglia Handle / Poignée Griff / Tirador	Push-Pull	Maniglia Handle / Poignée Griff / Tirador	Push-Pull
1 Piano in stratificato e fianchi verniciati Stratified top and painted sides / Plan stratifié et panneaux latéraux vernis / Arbeitsplatte aus Schichtstoff und lackierte Seitenwände / Encimera de estratificado y laterales pintados	+ VFA			
2 Piano in vetro e fianchi verniciati Glass top and painted sides / Plan en verre et côtés peints / Arbeitsplatte aus Glas und lackierte Seitenwände / Encimera de vidrio y laterales pintados	+ VIV			
3 Piano in Corian® e fianchi verniciati Corian® top and painted sides / Plan en Corian® et panneaux latéraux vernis / Arbeitsplatte aus Corian® und lackierte Seitenwände / Encimera de Corian® y laterales pintados	+ VIC			
4 Piano e fianchi in Corian® Corian® top and Corian® sides / Plan et panneau latéraux en Corian® / Arbeitsplatte und Seitenwände aus Corian® / Encimera y laterales de Corian®	+ VIC			

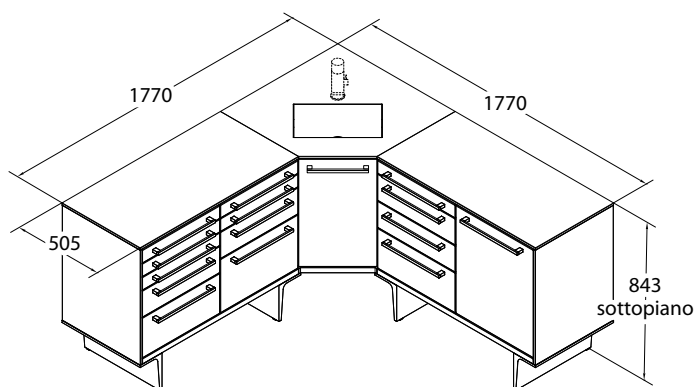

F

COMPOSIZIONE / COMPOSITION / COMPOSITION
ZUSAMMENSTELLUNG / COMPOSICIÓN

V5A + V4C + VAA + V4A + VPA

La composizione è comprensiva di bacinelle standard. Rubinetto escluso.

Trays included. Mixer excluded
Intérieurs de tiroirs inclus. Robinet pas compris.
Standard Schubladeneinsätze sind enthalten. Armatur ist ausgeschlossen.
La composición incluye bandejas estándar.
Grifo excluido.

	Con piedi / On feet Sur pieds / Mit Füßen / Con patas		Sospesa / Suspended / Suspendue Wandhängend / Suspendida	
	Maniglia Handle / Poignée Griff / Tirador	Push-Pull	Maniglia Handle / Poignée Griff / Tirador	Push-Pull
1 Piano in stratificato e fianchi verniciati Stratified top and painted sides / Plan stratifié et panneaux latéraux vernis / Arbeitsplatte aus Schichtstoff und lackierte Seitenwände / Encimera de estratificado y laterales pintados	+VFA			
2 Piano in vetro e fianchi verniciati Glass top and painted sides / Plan en verre et côtés peints / Arbeitsplatte aus Glas und lackierte Seitenwände / Encimera de vidrio y laterales pintados	+VIT			
3 Piano in Corian® e fianchi verniciati Corian® top and painted sides / Plan en Corian® et panneaux latéraux vernis / Arbeitsplatte aus Corian® und lackierte Seitenwände / Encimera de Corian® y laterales pintados	+VIC			
4 Piano e fianchi in Corian® Corian® top and Corian® sides / Plan et panneau latéraux en Corian® / Arbeitsplatte und Seitenwände aus Corian® / Encimera y laterales de Corian®	+VIC			

Descrizione / Description Description / Beschreibung / Descripción	M ³ Kg	Articolo Item / Article Artikel / Artículo
---	----------------------	--



L 1030 x P 200 x H 400 mm

PENSILE CON ANTA A RIBALTA VERNICIATA

Wall unit with painted pull-up door / Elément mural avec porte vernie avec ouverture vers le haut / Hängeschrank mit lackierten Tür mit Öffnung nach oben / Mueble colgante con puerta pintada con apertura hacia arriba

0,15
32

ALA10

PENSILE CON ANTA A RIBALTA IN VETRO

Wall unit with glass pull-up door / Elément mural avec porte en verre avec ouverture vers le haut / Hängeschrank mit Glastür mit Öffnung nach oben / Mueble colgante con puerta de vidrio con apertura hacia arriba

0,15
30

ALA10V

PENSILE CON ANTA A RIBALTA A SPECCHIO

Wall units with mirror pull-up door / Elément mural avec porte avec miroir avec ouverture vers le haut / Hängeschrank mit Spiegeltür mit Öffnung nach oben / Mueble colgante con puerta con espejo con apertura hacia arriba

0,15
30

ALA10S

Completo di:

n. 1 distributore di bicchieri; n. 1 distributore di sapone automatico con fotocellula;
n. 2 alloggiamenti per guanti o salviette; n. 1 alloggiamento per mascherine;
n. 2 portarotolo per carta e mantelline.

Complete of:

n. 1 glass dispenser; n. 1 photocell-controlled soap dispenser;
n. 2 spaces for gloves and serviettes; n. 1 place for face masks;
n. 2 paper roll and cape carriers.

Composé de:

n. 1 distributeur de gobelets; n. 1 distributeur de savon automatique avec cellule photoélectrique;
n. 2 logements pour gants ou serviettes; n. 1 logement pour masques;
n. 2 supports de rouleau pour papier et capes.

Komplett mit:

n. 1 Verteiler von Bechern; n. 1 automatischer Seifenspender mit Lichtschranke;
n. 2 Platz für Handschuhe oder Servietten; n. 1 Steckplatz für Maskern;
n. 2 Papierrollenträger und Schulterumhänge.

Dotado de:

n. 1 dispensador de vasos; n. 1 dispensador de jabón automático con fotocélula;
n. 2 alojamiento para guantes servilletas; n. 1 alojamiento para mascarillas; n. 1 alojamiento para mordazas y/o cánulas; n. 2 porta rollo para papel y capas.

Descrizione / Description Description / Beschreibung / Descripción	M ³ Kg	Articolo Item / Article Artikel / Artículo
---	----------------------	--



L 1530 x P 200 x H 400 mm

PENSILE CON ANTA A RIBALTA VERNICIATA

Wall unit with painted pull-up door / Elément mural avec porte vernie avec ouverture vers le haut / Hängeschrank mit lackierten Tür mit Öffnung nach oben / Mueble colgante con puerta pintada con apertura hacia arriba

0,22
51

ALA15

PENSILE CON ANTA A RIBALTA IN VETRO

Wall unit with glass pull-up door / Elément mural avec porte en verre avec ouverture vers le haut / Hängeschrank mit Glastür mit Öffnung nach oben / Mueble colgante con puerta de vidrio con apertura hacia arriba

0,22
49

ALA15V

PENSILE CON ANTA A RIBALTA A SPECCHIO

Wall units with mirror pull-up door / Elément mural avec porte avec miroir avec ouverture vers le haut / Hängeschrank mit Spiegeltür mit Öffnung nach oben / Mueble colgante con puerta con espejo con apertura hacia arriba

0,22
49

ALA15S

Completo di:

n. 1 distributore di bicchieri; n. 1 distributore di sapone automatico con fotocellula;
n. 3 alloggiamenti per guanti o salviette; n. 1 alloggiamento per mascherine;
n. 1 alloggiamento per bavagli o canule; n. 2 portarotolo per carta e mantelline.

Complete of:

n. 1 glass dispenser; n. 1 photocell-controlled soap dispenser;
n. 3 spaces for gloves and serviettes; n. 1 place for face masks;
n. 1 place for bibs and cannulas; n. 2 paper roll and cape carriers.

Composé de:

n. 1 distributeur de gobelets; n. 1 distributeur de savon automatique avec cellule photoélectrique; n. 3 logements pour gants ou serviettes; n. 1 logement pour masques;
n. 1 logement pour bavoires ou canules; n. 2 supports de rouleau pour papier et capes.





Komplett mit:

n. 1 Verteiler von Bechern; n. 1 automatischer Seifenspender mit Lichtschranke;
n. 3 Platz für Handschuhe oder Servietten; n. 1 Steckplatz für Masken;
n. 1 Steckplatz für Lätzchen oder Kanülen; n. 2 Papierrollenträger und Schulterumhänge.

Dotado de:

n. 1 dispensador de vasos; n. 1 dispensador de servilletas; n. 1 dispensador de jabón automático con fotocélula; n. 3 alojamientos para guantes o servilletas;
n. 1 alojamiento para mascarillas; n. 1 alojamiento para mordazas o cánulas; n. 2 porta rollo para papel y capas.

	Descrizione / Description Description / Beschreibung / Descripción	Dim. Dim. / Dim. Maß / Dim. mm	M³ Kg	Articolo Item / Article Artikel / Artículo
	LAMPADA A LED LED lamp Lampe à LEDs LED-Leuchte Lámpara de LED	L = 1030		LED10
		L = 1530		LED15
	DISTRIBUTORE DI SAPONE SOAP DISPENSER DISTRIBUTEUR DE SAVON SEIFENSPENDER DISPENSADOR DE JABÓN	Manuale Manual	- 1,2	DSM
		Con fotocellula Photocell-controlled Avec cellule photoélectrique Mit fotozelle Con fotocèleula	- 1,2	DSF
	ALLOGGIAMENTO per guanti o salviette SPACE for gloves and serviettes LOGEMENT pour gants ou serviettes STECKPLATZ für Handschuhe oder Tücher ALOJAMIENTO para guantes o servilletas	L 240 x P 130	- 0,6	ALAPG
	ALLOGGIAMENTO per mascherine PLACE for face masks LOGEMENT pour masques STECKPLATZ für Masken ALOJAMIENTO para mascarillas	L 185 x P 105	- 0,5	ALAPM
	ALLOGGIAMENTO per bavagli o canule PALCE for bibs and cannulas LOGEMENT pour bavoires ou canules STECKPLATZ für Lätzchen oder Kanülen ALOJAMIENTO para mordazas o cánulas	L 185 x P 125	- 0,9	ALAPT
	PORTAROTOLO per carta o mantelline Paper roll and cape CARRIER SUPPORT DE ROULEAU pour papier et capes PAPIERROLLENTÄGER und Schulterumhänge PORTA ROLLO para papel y capas	L 322	- 0,7	ALAPR
	MENSOLA Shelf Etagère Regal Repisa	L 250	-0,8	ALAME25
		L 500	-1,6	ALAME50
		L 1000		ALAME100
		L 1500		ALAME150
	FONDO Bottom Fond Unterseite Parte inferior	L 1030	-0,8	ALAF10
		L 1530	-1,6	ALAF15

	Descrizione / Description Description / Beschreibung / Descripción	M³ Kg	Articolo Item / Article Artikel / Artículo
 <p>L 430 x P 500 x H 845 mm</p>	<p>CARRELLO PORTA APPARECCHI con prese multiple EQUIPMENT-CARRYING TROLLEY with multiple power sockets CARIOT POUR APPAREILS avec prises multiples Gerätetragewagen (Trolley für Geräte) mit Steckdosenleisten CARRO PORTA EQUIPOS con tomas múltiples</p>	<p>0,22 ----- 23</p>	<p>LUNA</p>
 <p>L 430 x P 500 x H 845 mm</p>	<p>CARRELLO PORTA APPARECCHI con prese multiple e PANNELLI COLORATI* EQUIPMENT-CARRYING TROLLEY with multiple power sockets AND COLOURED PANELS* CARIOT POUR APPAREILS avec prises multiples ET PANNEAUX EN COULEUR* Gerätetragewagen (Trolley für Geräte) mit Steckdosenleisten und farbige Paneele* CARRO PORTA EQUIPOS con tomas múltiples y PANELES DE COLORES*</p> <p>* Tinte RAL / RAL colors / couleurs RAL / RAL Farbe / colores RAL</p>	<p>0,22 ----- 23</p>	<p>LUNAV</p>
 <p>L 430 x P 500 x H 845 mm</p>	<p>CARRELLO PORTA APPARECCHI con cassetto e prese multiple EQUIPMENT-CARRYING TROLLEY with drawer and multiple power sockets CARIOT POUR APPAREILS avec tiroir et prises multiples Gerätetragewagen (Trolley für Geräte) mit Schublade und Steckdosenleisten CARRO PORTA EQUIPOS con cajones y tomas múltiples</p>	<p>0,22 ----- 2,6</p>	<p>LUNAC</p>
 <p>L 430 x P 500 x H 845 mm</p>	<p>CARRELLO PORTA APPARECCHI con cassetto e prese multiple e PANNELLI COLORATI* EQUIPMENT-CARRYING TROLLEY with drawer, multiple power sockets AND COLOURED PANELS* CARIOT POUR APPAREILS avec tiroir, avec prises multiples ET PANNEAUX EN COULEUR* Gerätetragewagen (Trolley für Geräte) mit Schublade, Steckdosenleisten und farbige Paneele* CARRO PORTA EQUIPOS con cajón, tomas múltiples y PANELES DE COLORES*</p> <p>* Tinte RAL / RAL colors / couleurs RAL / RAL Farbe / colores RAL</p>	<p>0,22 ----- 26</p>	<p>LUNACV</p>

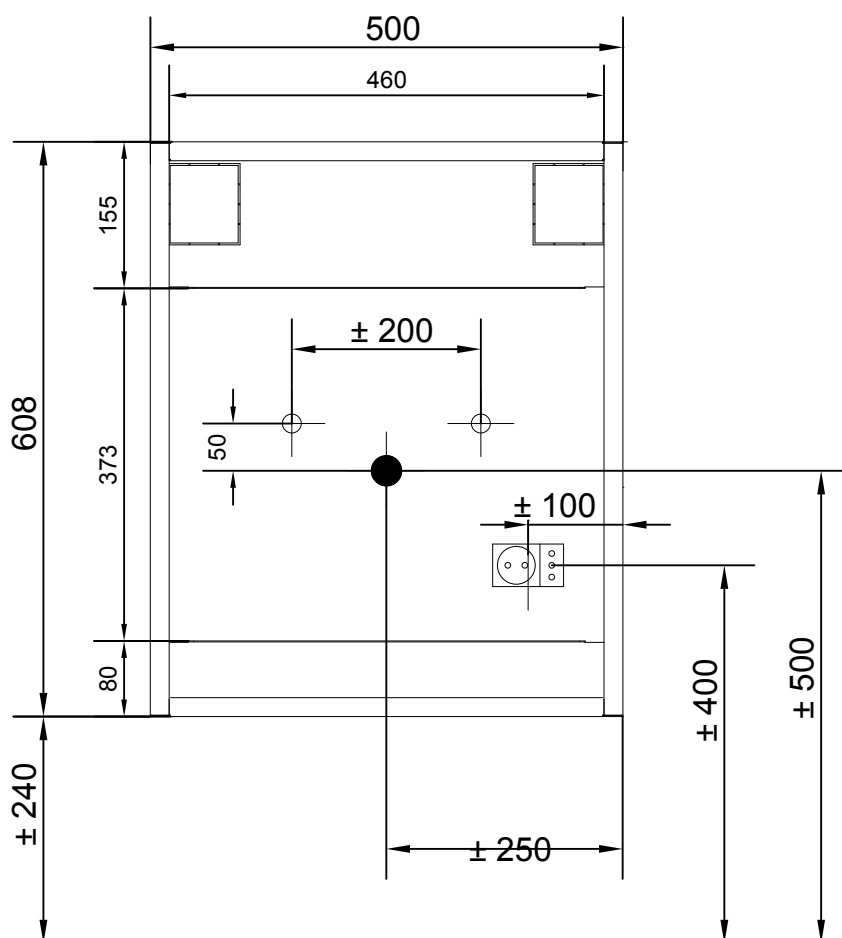

CONDIZIONI GENERALI DI VENDITA

General terms of sale / Conditions generales de vente

Allgemeine Verkaufsbedingungen / Condiciones generales de venta



Il presente listino sostituisce e annulla tutti i precedenti e può essere modificato in qualsiasi momento senza preavviso. I prezzi si intendono al netto di iva. **L'imballo non è compreso nel prezzo.** L'installazione è a carico del cliente.

L'ordine, e ogni modifica ad esso, dovrà essere inoltrato per iscritto e sarà da considerarsi accettato solo dopo l'invio di una conferma da parte di Loran srl. I termini fissati per la spedizione non sono tassativi e in nessun caso potranno costituire pretesto per ritardi di pagamento o richiesta di risarcimento.

La merce viaggia a rischio e pericolo del committente, franco stabilimento Loran srl a Pieve di Soligo. Se non indicato per iscritto, la merce sarà spedita col mezzo ritenuto più opportuno da Loran srl. **Eventuali reclami di trasporto devono essere fatti al momento della consegna direttamente al vettore.**

Eventuali difetti di fabbricazione devono essere comunicati a mezzo raccomandata alla sede Loran srl di Pieve di Soligo entro 8 giorni dalla data di ricevimento merce, anche se segnalati prima in altra forma. In ogni caso non danno diritto al cliente di sospendere i pagamenti.

Nessun materiale dovrà essere reso senza nostra autorizzazione scritta. I resi autorizzati ci dovranno pervenire in porto franco accompagnati da documento di trasporto che indichi il numero e la data della fattura relativa alla fornitura originaria e saranno gravati del 15% per spese generali.

Il materiale di produzione Loran srl ha garanzia di anni due, salvo eventuali danni o manomissioni causati dall'utilizzatore.

La merce venduta rimane di proprietà della venditrice fino al pagamento totale da parte dell'acquirente. In caso contrario la venditrice si riserva la facoltà di ritirarla in qualsiasi momento. Ogni controversia sarà competenza del foro di Treviso (Italia)

This price list can be modified at any time, without notice. The prices do not include vat. **Packing is not included in the price.** Installation shall be charged to the customer.

Order as well as any modifications of such orders shall be made in writing and shall be considered accepted upon our written confirmation. Delivery terms are not binding and under no circumstance may they be used as a pretext to justify delays in payment or claims for compensation.

The goods travel at the purchaser's risk on a ex-works basis from our factory in Pieve di Soligo (Italy): unless otherwise specified in writing, the goods will be shipped with the means of transport considered most suitable by our company. The goods shall be checked by the receiver as soon as they reach their destination and **any claim for damages shall be filed directly with the carrier.**

Any manufacturing fault shall be immediately communicated by registered letter to our offices in Pieve di Soligo within 8 days after the goods have been received, and may also be communicated in other additional ways. By no means shall manufacturing defects entitle the purchaser to stop payments.

No goods shall be returned without our written authorization. Authorized returned goods shall be sent to us free port, together with a "returned goods" note showing the number and date of our original invoice related to such. 15% of total value shall be charged to our customer.

All Loran products are guaranteed for two years. The warranty shall no longer be valid if the product has been damaged or tampered with by the user.

Goods sold remain property of the seller until fully paid by the buyer. Should this not be the case, the seller shall be entitled to withdraw its goods at any time. In the event of any and all disputes, competent court shall exclusively be the court of Treviso (Italy).

CONDIZIONI GENERALI DI VENDITA

General terms of sale / Conditions generales de vente

Allgemeine Verkaufsbedingungen / Condiciones generales de venta



Cette liste de prix est susceptible d'être modifiée à n'importe quel moment sans préavis. Les prix sont exprimés HT. **Les prix ne comprennent pas l'emballage.** L'installation est à la charge du client.

La commande, et toute modification éventuelle à celle-ci, devra être transmise par écrit et ne pourra être considérée acceptée qu'après l'envoi d'une confirmation écrite de notre part. Les délais fixés pour l'expédition ne constituent pas un terme de rigueur et ne pourront en aucun cas constituer prétexte pour retarder les paiements ou pour exiger un remboursement ou des dommages.

La marchandise voyage aux risques et périls du client, franco départ-usine Loran srl de Pieve di Soligo (Italie): en absence d'instructions écrites précises de la part du client, la marchandise sera envoyée par le moyen que nous jugerons le plus indiqué. **Les éventuelles réclamations concernant le transport devront être faites directement au transporteur au moment même de la livraison.**

Les éventuels défauts de fabrication devront être signalés, par lettre recommandée dans les 8 jours à compter de la date de réception de la marchandise, à Loran srl de Pieve di Soligo; et cela, même si déjà signalés au travers un autre moyen ou forme. De toute façon, il est entendu qu'une éventuelle réclamation ne donne en aucun cas le droit au client d'interrompre les paiements.

Aucun matériel ne pourra être rendu sans notre autorisation écrite. Les retours autorisés de marchandise devront nous parvenir franco de port et munis d'un bulletin de transport officiel indiquant entre autre le numéro et la date de la facture relative à la commande d'origine. Il est entendu que les marchandises rendues seront grevées de 15% pour cause de frais généraux.

Le matériel de Loran srl production bénéficie d'une garantie 2 ans, sujette à déchéance en cas de dégâts provoqués par l'utilisateur ou, de quelque manière, imputables à celui-ci.

Il est entendu que jusqu'au paiement complet par de l'acheteur de la marchandise vendue, celle-ci reste la propriété de l'entreprise vendeuse qui aura donc la faculté de retirer la marchandise à n'importe quel moment en cas de défaut, même partiel, de paiement. Il est entendu que tout différent ou litige entre les parties sera du ressort du tribunal de Treviso (Italie).

Diese Preisliste kann jederzeit und ohne Vorankündigung geändert werden. Die Preise verstehen sich zuzüglich Mehrwertsteuer. **Die Preise verstehen sich ausschließlich Verpackung.** Die Installation erfolgt auf Kosten des Kunden.

Der Auftrag und jede diesbezügliche Änderung hat schriftlich zu erfolgen und gilt erst nach unserer Auftragsbestätigung als angenommen. Die Lieferdaten sind nicht bindend und berechtigen keinesfalls zu Zahlungsverzögerungen oder Schadenersatzforderungen.

Die Ware reist auf alleinige Gefahr des Auftraggebers ab unserem Firmensitz in Pieve di Soligo (Italien): falls nicht anders schriftlich vereinbart, wird die Ware mit dem von uns als geeignet erachteten Transportmittel befördert. **Eventuelle Beanstandungen bezüglich des Transports sind bei der Anlieferung direkt dem Frachtführer zu melden.**

Fabrikationsfehler sind unserem Firmensitz in Pieve di Soligo innerhalb von 8 Tagen nach Erhalt der Ware per Einschreiben zu melden, auch wenn Sie vorher bereits in anderer Form mitgeteilt wurden. In jedem Fall berechtigen Sie den Kunden nicht zur Einstellung der Zahlungen.

Materialrückerstattungen dürfen nur mit unserer schriftlichen Genehmigung erfolgen. Die genehmigten Rückerstattungen haben Frachtfrei mit einem Transportschein zu erfolgen, auf dem die Rechnungsnummer und das Rechnungsdatum bezüglich der ursprünglichen Lieferung vermerkt sind, wobei 15% für allgemeine Kosten berechnet werden.

Das Material von Loran srl hat eine zweijährige Garantie, außer bei Schäden oder unsachgemäßer Behandlung durch den Anwender.

Die verkaufte Ware bleibt Eigentum des Verkäufers bis zur vollständigen Zahlung seitens des Käufers. Andernfalls behält sich der Verkäufer das Recht vor, die Ware jederzeit abzuholen. Für jegliche Streitigkeiten ist das Gericht von Treviso (Italien) zuständig.

La presente lista de precios puede ser modificada en cualquier momento y sin previo aviso. Los precios se consideran sin IVA. **El embalaje no está incluido en el precio.** La instalación está a cargo del cliente.

El pedido, y toda modificación del mismo, se deberá enviar por escrito y se considerará aceptado sólo después del envío de una confirmación por parte de Loran srl. Los plazos fijados para la expedición no son taxativos y en ningún caso podrán constituirse en un pretexto para retrasar el pago o pedir resarcimiento.

La mercancía viaja por cuenta y riesgo del cliente, desde Loran srl en Pieve di Soligo (Italia). Si no estuviera especificado por escrito, la mercancía será enviada por el medio de transporte considerado más conveniente por Loran srl. **Eventuales reclamos por el transporte se deberán realizar en el momento de la entrega directamente al transportista.**

Los defectos de fabricación deberán comunicarse mediante carta certificada a la sede de Loran srl de Pieve di Soligo, dentro de los 8 días a partir de la fecha de recepción de la mercancía, incluso si se comunicaron antes por otro medio. En cualquier caso esto no otorga derecho al cliente para suspender los pagos.

Ningún material podrá entregarse sin nuestra autorización escrita. Las entregas autorizadas deberán realizarse en puerto franco acompañadas por el documento de transporte que indique el número y la fecha de la factura correspondiente al suministro original y estarán gravados con 15% para gastos generales.

El material producido por Loran srl tiene una garantía de dos años, excepto eventuales daños o alteraciones causados por el usuario.

La mercancía vendida continuará perteneciendo al vendedor hasta el pago total por parte del comprador. En caso contrario el vendedor se reserva la facultad de retirarla en cualquier momento. Toda controversia será competencia de los tribunales de Treviso (Italia).

Loran
everyday passion



LORAN srl • Via della Lira, 397 zona ind. • 31053 Pieve di Soligo • TV • Italy
Tel. +39 0438 842603 • Fax +39 0438 980233 • loran@loran.it • www.loran.it